

Assun Motor

Product Manual

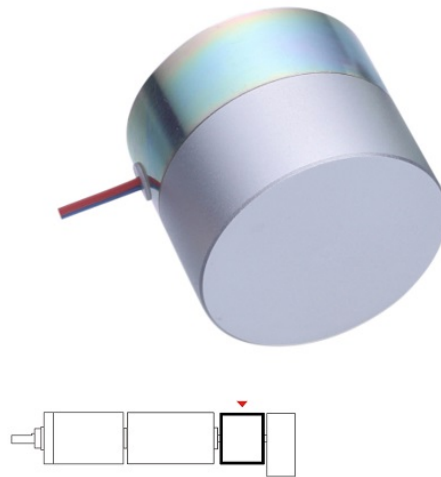

For Power-Off Static Brake

of

AM-BK2423LE Series

1st edition. October, 2019.

All Rights Reserved

Assun Motor Inc.

Assun Motor Pte Ltd

Shenzhen Zhengyuan Motor Co., Ltd

Contents

Assun Motor.....	1
Product Manual.....	1
1. About the Manual.....	3
1.1 Validity of This Document	3
1.2 Using This Document.....	3
1.3 Definition of Terms	4
1.4 Definition of Symbols.....	4
2. Product Safety.....	5
2.1 Intended Product Usage	5
2.2 Product Usage Safety	5
2.3 Product Disposal/Recycling	7
3. Product Series Information.....	8
3.1 Product Series Structure Introduction.....	8
3.2 Product Model Information	9
4. Product Function and Usage	10
4.1 Installation and Power Connection	10
4.2 Brake Control.....	10
5. Maintenance.....	10
Appendix	11
Appendix 1. Series Product Parameters	11
Appendix 2. Specified Product Drawing and Parameters	11
Contact.....	11

1. About the Manual

1.1 Validity of This Document

The product manual document here is used for AM-BK2423LE series product by Assun Motor which is power-off static brake. The manual has made detailed description to the safety and functional usage of this brake product series. It helps the professional user to install and connect the brake, and also guide the user in relevant applications.

All data in this manual are based on the actual manufacturing and standard testing condition of AM-BK2423LE series product. Standard testing condition is when the brake installed horizontally and environment temperature is 25°C.

For relevant parameter summaries of the product series, please refer to Appendix 1 “Product Series Parameters”; For specified standard model or customized model, please refer to Appendix 2 “Detailed Product Drawing and Parameter”.

1.2 Using This Document

Please read this document carefully before install and set-up the product. Please pay extra attention to the second chapter “Product Safety”, and strictly follow the warnings and instructions.

Please retain this document throughout the entire working life of the product, and keep the document accessible to the operating and, if necessary, maintenance personnel at all times.

Pass a copy of this document on to any subsequent owner or user of the product.

1.3 Definition of Terms

Term	Meaning
CW/CCW	Clockwise/Counter Clockwise
VIL/VIH	Voltage Input Low / Voltage Input High
Cable	Power Connection Cable
GND	Ground / Negative Pole
Vcc	Direct Current Voltage
RPM	Revolution per Minute

1.4 Definition of Symbols



Caution! Hazard to persons. Disregard may lead to injury.



Warning! Improper operation will cause product damage.



Caution! Hazardous due to hot surface. Disregard may lead to burns.

2. Product Safety

2.1 Intended Product Usage

The Assun Motor AM-BK2423LE series power-off static brake, which we are describing here in this manual, are used to hold the motor shaft in static condition and prevent any un-wanted shaft move. It is suitable for many DC drive systems, can be used for robotic braking, Z-axis brake and servo system static brake, etc.

Usually this brake will be connected to a servo controller and when the motor stops, the controller will dis-charge the brake and then it holds the shaft to prevent shaft move.

The product is not suitable for operation in environments with high humid or excessive dust. During the operation, please follow the parameter limits in the appendices so as to achieve the optimum operational performance and longest product lifetime.

For usage of product in special environment, please contact our local sales or service staff for consultancy and get the relevant advice or customized service.

This product is NOT SUITABLE for applications where the failure of the product could result in the death of an individual or group of individuals.

2.2 Product Usage Safety



The product is a high-speed rotating device. Please make sure the product is properly mounted before commencement of operation to prevent potential hazards to people or equipment. Please refer to Chapter 4.1 of this manual for further installation guidance.



Motor surface temperature could be high after long term operation. Please exercise caution when touching or handling the product.



Power supply must be filtered DC. The input voltage shall be according to the rated value for normal braking performance. Lower voltage may lead to decrease in braking force and cause deteriorating performance.



Power supply connection must be strictly according to the designated positive and negative polarity. If the power supply is reversed, it may seriously affect the brake performance and cause defects. For detailed power connection guidance, refer to Chapter 4.1.



Please install the brake in an environment with good heat sinking and/or ventilation. Inadequate heat dissipation will lead to the brake winding temperature exceeding the limit of 120°C and cause thermal damage to the internal electronic parts and winding, resulting in malfunction and/or failure.



Please use the brake according to the parameter limits in the appendix, otherwise it may cause the brake to be exceed current limits or overheat, which could lead to irreversible damage to the brake.



The brake is not suitable for operating in high humid and dusty environments. High humidity or excessive dust could affect brake performance and shorten the brake lifetime.



The product is a precision DC static brake with sensitive internal electronic components. Please do not personally disassemble the product.

2.3 Product Disposal/Recycling

This series of motor products is manufactured with multiple types of metals, alloy materials, chemical adhesives and lubricants. Please dispose it properly as recyclable material. For a detailed product material listing please refer to Chapter 3.1.

3. Product Series Information

3.1 Product Series Structure Introduction

AM-BK2423LE series brake is a series of precision DC power-off static brake with stator winding and rotating brake pad. Case diameter is $\phi 24\text{mm}$, case length is 23mm, rated power 4.0W, with a net weight of approximately 80.8g. For detailed series information and parameters please refer to Appendix 1.

The series product is power-off brake, which is to say when the brake is discharged, it generates brake force. And when the brake is energized, shaft will rotate freely with the braking pad.

When charged, the winding will generate magnetic field and push the braking pad to release the shaft. And when not charged, the braking pads will be connected with each other to hold the shaft.

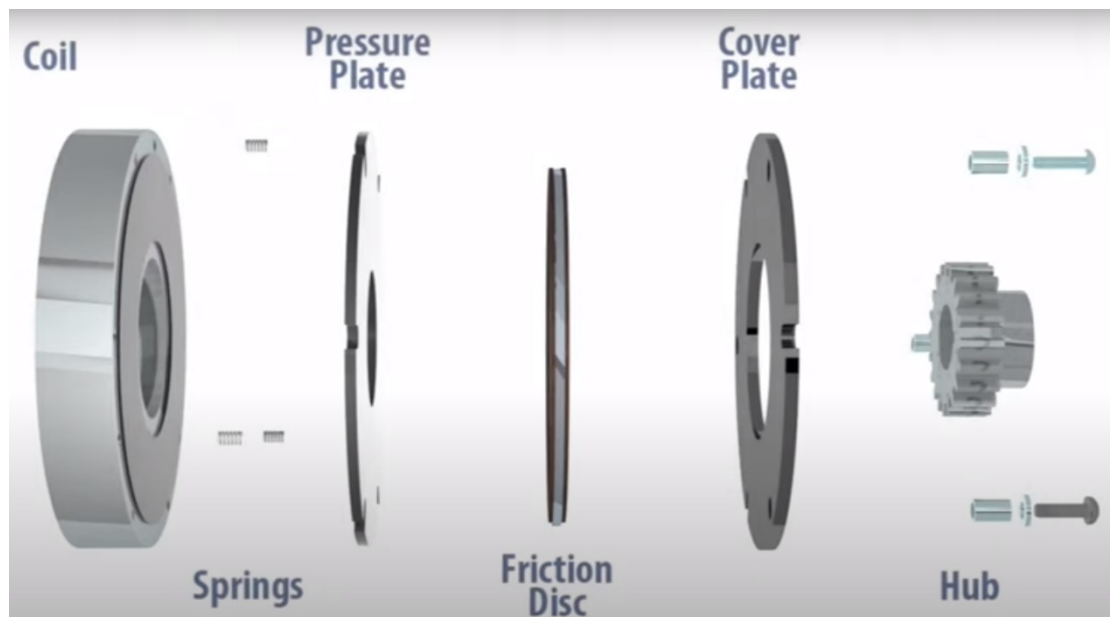

Illustration 1. Exploded Product View

This series of product are manufactured using materials using multi-types of metal, alloy material and chemical products. Specific material usage as shown in Table 1.

Table 1. Product Material Matrix

Components	Housing	Winding	Bearing	Magnet
Material	Aluminum Alloy	Copper	Stainless Steel	Sintered NdFeB
Components	Glue	Grease	Cushion	Cable
Material	Epoxy Resin	Fluorine Grease	Stainless Steel	Copper & Plastic

3.2 Product Model Information

To make it convenient for the customer to choose a specific part number or model and understand the part number methodology, please refer below in Illustration 2 the explanation for model number composition principle.

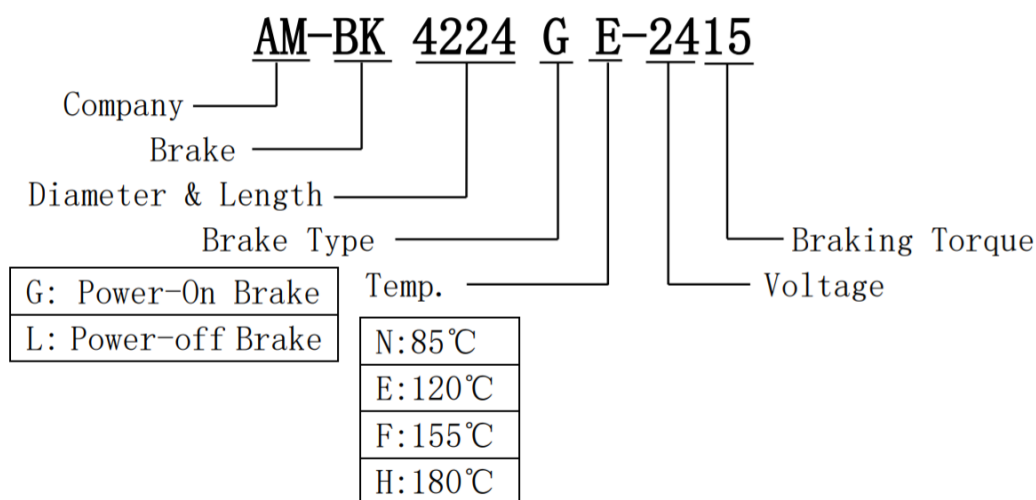

Illustration 2. Part Number Nomenclature

Customers can choose suitable products based on their types and characteristics shown in the part number methodology. If products with special characteristics are required, please contact our regional sales person for customized service.

4. Product Function and Usage

The Product Series has two power supply cables, they are red cable (connect to power supply positive) and blue cable (connect to power supply negative).

4.1 Installation and Power Connection

Brake must be properly and securely mounted., typically utilizing the treaded holes on the housing to fix the brake. It will be proposed to install the brake to metal parts, or installed in well ventilated environments for better heat dissipation.

 There are two AWG22# power cables, one is red cable that should be connected to the positive of power supply, the other is blue cable which should be connected to the negative of power supply. The power connection must obey the indication above. If the power supply is inadvertently reversed, it may seriously damage the internal electronics causing malfunction of the brake.

4.2 Brake Control

When brake discharged, the braking pads will be pressed against each other and give braking torque.

 Note: This is a static brake, so it will be recommended to brake in zero speed or when speed under 40 RPM for the optimum lifetime.

5. Maintenance

The product series is maintenance free, please do not disassemble in person. There are no repairable components inside the motor. Regarding any quality issue or maintenance needs, please contact our regional service person for relevant technical support.

Ignoring this warning will void the warranty.

Appendix

Appendix 1. Series Product Parameters

Appendix 2. Specified Product Drawing and Parameters

Contact

Singapore

Tel: +65 6532-5243

Email: info@assunmotor.com

Add: #06-05, 1092 Lower Delta Road. Singapore 169203.

China

Tel: +86 755-8368-8818

Email: info@assunmotor.com

Add: 7th Floor, Blk 6, Yongping Industrial Area, 9 Tongfu Road. Shenzhen, P.R.China.

USA

Tel: +1 760-451-2723

Email: beauche@roadrunner.com

Add: Suit F208, 6370 Lusk Boulevard San Diego, CA 92121-2760 USA