

AM-32P Series

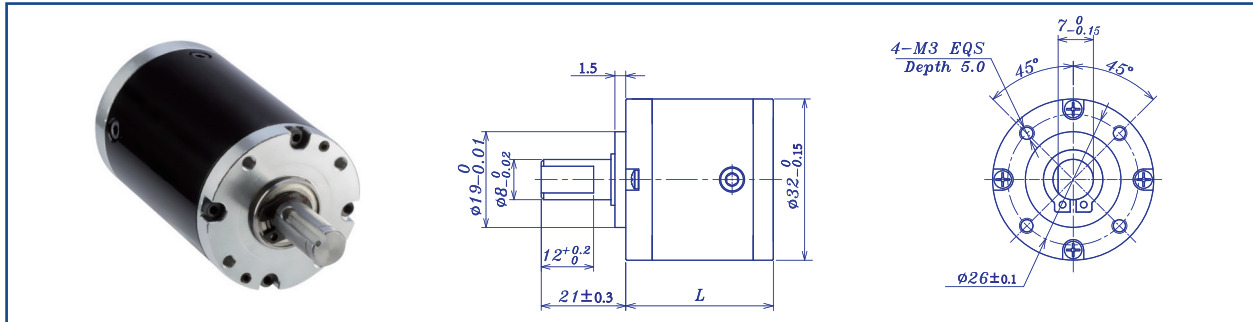

GEARBOX CHARACTER

Gear type	Straight teeth	Average backlash on load	$\leq 2^\circ$
Output shaft	Stainless steel hardened	Radial Play	≤ 0.1
Main gear	Alloy Steel	Permissible axial load	$\leq 110N$
Ring gear	Steel	Permissible force press fits	$\leq 200N$ (5mm from mounting face)
Adapter plate	Aluminium alloy	Recommended inut speed	$\leq 8000RPM$
Bearing AT output	Ball bearing	Operating temperature range	$-20^\circ C \sim +100^\circ C$
Axial play	0-0.3	Operating humidity range	10-90%RH
Directions	CW/CCW		

GEARBOX DATA

Number of stage	1	2			3			4		
Reduction ratio X:1	3.4	12	18	28	40	74	129	296	534	1016
	3.8	13	19	29	45	85	152	327	637	1136
	4.4	15	20	35	50	95	184	375	760	1304
	5.3	17	23	44	56	106	233	405	860	1556
	6.7		26		65	121	296	447	965	1975
Reduction ratio absolute	24/7	576/49	18/1	441/16	13824/343	189/2		85169/288	194481/256	
	23/6	92/7	484/25	88/3	2208/49	3381/32		122452/375	7744/9	
	22/5	529/36	16/18	35/1	1053/21	4851/40		234256/625	15435/16	
	21/4	253/15	231/10	400/9	12167/2	1936/15		25921/64	64000/63	
	20/3		230/9		5819/90	3200/21		53361/100	92000/81	
					5566/75	735/4		101871/160	35200/27	
				10648/125	700/3			14000/9		160000/81
Gearbox length "L" (mm)	31.2	38.7			46.2			53.7		
Max. continuous torque (N.m)	1.9	2.5			3.2			3.9		
Max. intermitten torque (N.m)	2.9	3.8			4.8			5.7		
Gearbox efficiency	90%	81%			72%			65%		
Moment of inertia range (g.cm ²)	1.5	1			1			1		
Gearbox weight approx (g)	135	168			200			236		
Gearbox model	AM-32PA-X-01	AM-32PB-X-01			AM-32PC-X-01			AM-32PD-X-01		

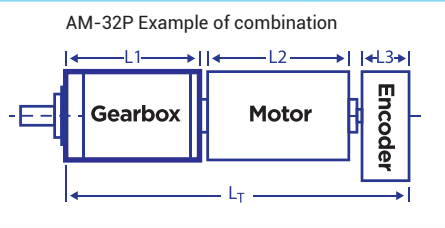

Recommend Motor:
Coreless Motor: (w/E)
AM-CL2831MAN
AM-CL2845MAN
Brushless Motor (w/E)
AM-BL2845AN

Recommend Encoder:
Suitable for Coreless Motor
Encoder S: AM-EN1611S***
Suitable for Brushless Motor
Encoder S: AM-EN1611S***
Encoder T: AM-EN2412T***

INPUT GEARBOX DATA					
Modulus	0.45				
Press angle	20°				
Teeth number	9	12	15	18	21
Max gear hole "A"	2.0	3.0	4.0	5.0	6.0
Max motor shaft	2.0	3.0	4.0	5.0	6.0
Motor dimension "D"	10.0		16.0		

GEARBOX MOTOR LENGTH "LT"		
Gear motor length L _T	72.9	95.7
Gearbox length L ₁	31.2	38.7
Motor length L ₂	31	45
Encoder length L ₃	10.7	12

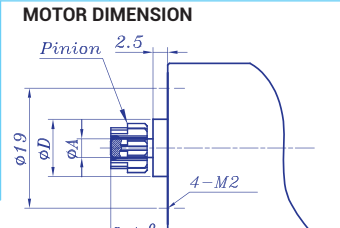

Download datasheet: <https://assunmotor.com/documents-download>

Visit Our Website and Online Shop at <https://assunmotor.com> Contact: info@assunmotor.com