

PLANETARY GEARBOX
HIGH PERFORMANCE SERIES

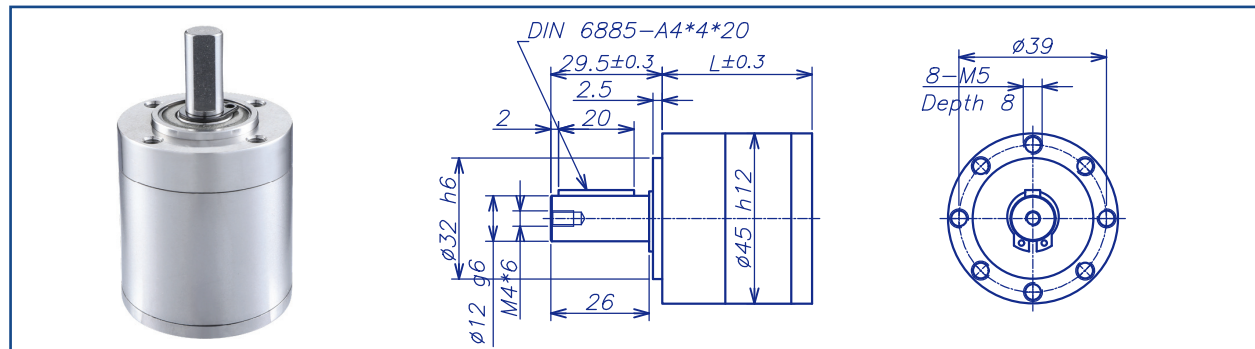

AM-45HP Series



GEARBOX CHARACTER

Gear type	Straight teeth	Radial Play (10mm from flange)	max 0.1mm
Output shaft	Stainless steel hardened	Permissible force press fits	max. 500 N
Main gear	Alloy Steel hardened	Permissible axial load (dynamic)	max. 200N
Ring gear	Alloy Steel hardened	Recommended input speed	10000RPM
Adapter plate	Stainless steel hardened	Operating temperature range	-40°C ~ +100°C
Bearing AT output	Ball bearing	Operating humidity range	10-90%RH
Axial play	0-0.3	Number of stages	1 2 3 4
Directions	CW/CCW	Permissible load (18mm from flange)	315N 470N 550N 550N

GEARBOX DATA

Number of stage	1				2				3		4			
Reduction ratio X:1	3.3	4.0	5.2	8	11	17	32	37	107	178	300	469	853	
					13	27	42	44	139	193	361	721	1109	
					16			53		213	427			
					21			58		231	462			
								69		277	555			
Reduction ratio absolute	10/3	4/1	26/5	8/1	100/9	52/3	32/1	1000/27	320/3	1600/9	2704/9	35152/75	2560/3	
					40/3	676/25	208/5	400/9	416/3	5200/27	5408/15	10816/15	3328/3	
					16/1			160/3		640/3	1280/3			
					104/5			520/9		2080/9	4160/9			
								208/3		832/3	1664/3			
Motor shaft max. diameter (mm)	8	6	6	3	8	6	3	8	3	8	6	6	3	
Gearbox length "L" (mm)	39.6				51.6				63.6		75.6			
Max. continuous torque (N.m)	4				15				30		30			
Max. intermittent torque (N.m)	5				18.75				37.5		37.5			
Average backlash no load	0.7°				0.8°				0.8°		0.8°			
Gearbox efficiency	90%				81%				73%		65%			
Max. mass inertia (g.cm ²)	15.13				15.71				15.77		15.77			
Gearbox weight approx (g)	460				590				730		850			
gearbox model	AM-45HPA-X				AM-45HPB-X				AM-45HPC-X		AM-45HPD-X			

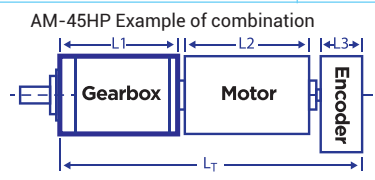

INPUT GEARBOX DATA

Modulus	0.6			
Press angle	20°			
Teeth number	9	15	21	27
Max gear hole "A"	3.0	6.0	8.0	8.0
Max motor shaft	3.0	6.0	8.0	8.0

MOTOR DIMENSION

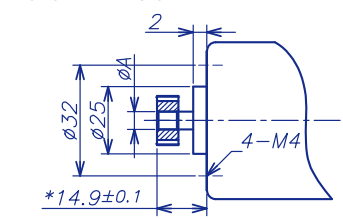

Recommend Motor:	Recommend Encoder:
Coreless Motor (w/E): AM-CL35***	Suitable for Coreless Motor Encoder S: AM-EN2211S*** Encoder T: AM-EN2412T***
Brushless Motor (w/E): AM-BL36*** AM-BL40*** AM-BL45*** AM-BD36***	Suitable for Brushless Motor Encoder S: AM-EN2211S*** Encoder T: AM-EN3612T***

GEARBOX MOTOR LENGTH "LT"

Gear motor length LT	134.3	187.6
Gear box length L1	63.6	75.6
Motor length L2	60	100
Encoder length L3	10.7	12

Download datasheet: <https://assunmotor.com/documents-download>

Visit Our Website and Online Shop at <https://assunmotor.com> Contact: info@assunmotor.com

PLANETARY GEARBOX